



# INSTRUCTION AND MAINTENANCE MANUAL

## SEMAUTOMATIC SERVICING EQUIPMENT FOR AIR CONDITIONING SYSTEMS

**MODEL: 131  
RALLY 77L0**





**1 CONTENTS**

**1 CONTENTS ..... 2**

**2 INTRODUCTION ..... 4**

**3 GUARANTEE ..... 5**

**4 DESCRIPTION OF THE UNIT ..... 6**

**4.1 Intended use ..... 6**

**4.2 Identification of the unit and its components ..... 6**

**4.3 Technical characteristics ..... 9**

4.3.1 Main characteristics ..... 9

4.3.2 Power and consumption ..... 9

4.3.3 Noise levels ..... 9

4.3.4 Technical data concerning the instruments used ..... 9

**5 SAFETY ..... 10**

**5.1 General safety rules ..... 10**

**5.2 Guidelines for handling refrigerants ..... 11**

5.2.1 Glossary of terms ..... 11

5.2.2 Precautions for refrigerant storage ..... 12

5.2.3 Condition of the refrigerant and the system ..... 12

5.2.4 Recycling capacity ..... 12

5.2.5 General considerations ..... 12

**5.3 Safety devices ..... 13**

**5.4 Working environment ..... 13**

**6 USE ..... 14**

**6.1 Unpacking and checking the components ..... 14**

**6.2 Unit handling and storage ..... 14**

**6.3 Preparation for use ..... 14**

**6.4 Start-up ..... 15**

**6.5 Switching Off ..... 15**

**6.6 Internal tank filling phase ..... 16**

**6.7 Draining of incondensable gases ..... 18**

**7 MESSAGES ..... 19**

**7.1 Malfunction/error messages ..... 19**

**7.2 Function messages ..... 22**

**8 OPERATING DESCRIPTION ..... 23**

**8.1 Operating Modalities ..... 23**

**8.2 Modality of programming ..... 23**

**8.3 Editing ..... 24**

**9 PROGRAMS ..... 25**

**9.1 Recognition developed services ..... 25**

**9.2 Automatic Program ..... 26**

9.2.1 Model Search (Data base) ..... 27

9.2.2 User models ..... 28

**9.3 User Program ..... 29**

**9.4 Programming injection oil phase ..... 30**

**10 START OF PROGRAMMED CYCLES ..... 31**

**10.1 Recovery/recycling phase ..... 31**

**10.2 Vacuum phase ..... 32**

**10.3 Oil – UV injection ..... 33**

**10.4 Charging phase ..... 34**

**11 OTHER MENUS ..... 36**

**11.1 Filling internal tanks ..... 36**

**11.2 Diagnosis ..... 36**

11.2.1 Hoses emptying ..... 38



11.2.2	Suction of refrigerant through the A/C System .....	39
<b>11.3</b>	<b>PRINTER</b> .....	<b>40</b>
11.3.1	Repeat service report.....	40
11.3.2	Personalization of service report heading .....	40
<b>11.4</b>	<b>Service</b> .....	<b>41</b>
11.4.1	Setting language .....	41
11.4.2	Date and hour .....	41
11.4.3	Counters reset.....	41
<b>11.5</b>	<b>A4 Printout</b> .....	<b>42</b>
<b>11.6</b>	<b>Back up/restore</b> .....	<b>42</b>
<b>11.7</b>	<b>Exporting service history</b> .....	<b>42</b>
<b>11.8</b>	<b>Exporting refrigerant IN/OUT</b> .....	<b>43</b>
<b>12</b>	<b>STOP FOR LONG PERIODS</b> .....	<b>43</b>
<b>13</b>	<b>MAINTENANCE</b> .....	<b>43</b>
13.1	Changing the vacuum pump oil.....	44
13.2	Filter replacement .....	45
<b>14</b>	<b>DISPOSAL</b> .....	<b>46</b>
14.1	Environmental disposals .....	46
14.2	Disposal of recycled material.....	46
<b>15</b>	<b>FLOW DIAGRAM</b> .....	<b>47</b>



## 2 INTRODUCTION

Congratulations on your choice! The unit you have purchased is a direct result of our experience in this sector and it will guarantee you long-term, efficient operation.

This unit has been designed and built to ensure long lasting, high-level operating reliability with maximum safety for operators. ISC Systems has carefully selected all materials and components (combined with the adoption of generous safety margins) together with a management procedure based on continuous controls which, from the introduction of the product into the company, through storage and use in the workshop, will ensure the absence of damage, deterioration or malfunctions.

A further guarantee is provided by the strict factory tests and inspections to which the unit is subjected.

The user is therefore only responsible for ensuring proper use of the unit in accordance with the instructions found in this manual

It is essential that this unit is used according to the intended use specified in this manual. ISC Systems cannot be held responsible for any damage to persons, animals and/or objects due to improper use, different to that illustrated in this instruction manual.

ISC Systems reserves the right to modify the technical characteristics and appearance of the product without prior notification.

This unit is designed for use in commercial environments and light industry.

The purpose of this manual is to supply the user with all the information needed to use the unit, from the time of purchase through to the disposal of the said unit.

This manual may contain printing errors.

The manual has been devised to ensure maximum support for the personnel assigned to use and the maintenance of the unit. However, for any special needs or requests for technical assistance or spare parts, please contact our Customer Service department.

### Customer Assistance Service

ISC Systems.  
Via Comunità Carnica, 9  
33029 Villa Santina (UD)  
Tel. +39-0433-748425  
info@iscsystems.it



### **3 GUARANTEE**

ISC Systems assures the highest quality both of the raw materials and the technical procedures used in the production of its Equipment.

1. Check the integrity of the whole package at the receipt of the goods. Claims for transport damage must be notified to the Forwarder Company within 8 days from the date of good's receipt.
2. The Product ISC Systems is under warranty if it has been used and kept on the basis of what already specified in the user manual offered with the Unit.
3. Interventions under warranty on ISC Systems Products are performed by official ISC Systems Distributors or specialized personnel authorized by ISC Systems; transport charges are at Customer's charge.
4. For any contact with ISC Systems Distributors or with ISC Systems directly, it is always necessary to mention the Model and the Serial Number of the Equipment which are reported in the identification card.
5. The Product is granted by ISC Systems against possible defects of the materials employed for their construction starting from 12 months production date: components which will be considered defective will be replaced free of charge. Further extensions of the warranty terms offered by the ISC Systems Distributor will be granted exclusively under his responsibility.
6. Replacement of components during the warranty period of time, does not extend the validity of the same warranty but only of the defective component that will be covered by 3 months.
7. We suggest You to preserve the original package.
8. The operation of calibration of the pressure sensor as well as for load cells, the replacement of quick connectors or external plastic panels, electro valves cleaning and replacement of gaskets for HP /LP filling hoses must be considered as a procedure of installation or ordinary maintenance.

Warranty is not provided in such following cases:

- Components subjected to ordinary wear and tear of the equipment like for example: power cable and sockets, external plastic panels, stickers , external HP/LP charge hoses , HP/LP quick connectors and all components usually subjected to ordinary wear and tear.
- Damages caused by negligence, improper maintenance , transport, storage, uncorrect use.
- Anomalies on functioning caused by the use of the same Unit on A/C Equipment previously treated with "A/C Leak substances", fluids for flushing or which contain lubricants or refrigerants not suitable to the specific use or use of universal dye different from the type suggested by ISC Systems

## 4 DESCRIPTION OF THE UNIT

### 4.1 Intended use

**RALLY PRO** is an semiautomatic unit designed solely for use in automobile air-conditioning system maintenance.

Recovery, recycling, vacuum, oil injection, UV injection, system filling, flushing and leak test with nitrogen are the functions that **RALLY PRO** is capable of carrying out in complete safety and providing top-level performance in its category.



The unit is not designed to handle disposal operations! (see Chap. 4.2.1 Glossary of terms)

### 4.2 Identification of the unit and its components

The **RALLY PRO** is composed of a series of internal and external components as shown in the following photographs.

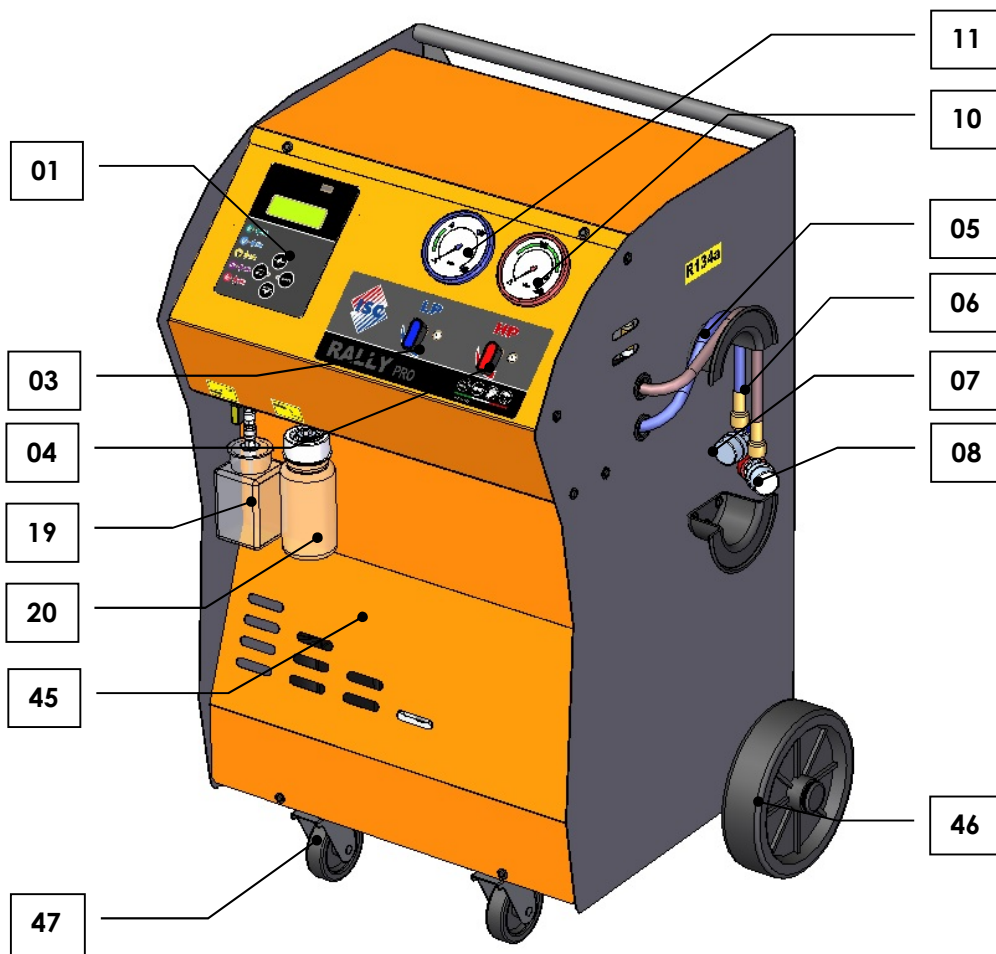



<b>ITEM</b>	<b>DESCRIPTION</b>
1	LOGIC BOARD
3	LOW PRESSURE VALVE
4	HIGH PRESSURE VALVE
5	BLUE FLEXIBLE HOSE 3000
6	RED FLEXIBLE HOSE 3000
7	LP QUICK CONNECTOR
8	HP QUICK CONNECTOR
9	OIL INJECTION VALVE
10	D80 HP GAUGE
11	D80 LP GAUGE
12	PRESSURE SENSOR -1/20 BAR
13	KPL DISTILLER
14	OIL SEPARATOR
15	FILTER
16	COMPRESSOR
17	VACUUM PUMP
18	60 Kg LOAD CELL
19	OIL INJECTION CONTAINER
20	OIL DRAIN CONTAINER
22	EXPANSION VALVE
25	RUBBER HOSE
26	RUBBER HOSE
28	HP SAFETY PRESSURE SWITCH
29	MECHANICAL FILTER
31	M/F CHECK VALVE
32	CHECK VALVE
33	INCONDENSABLES DISCHARGE VALVE
34	INTERNAL CONTAINER
42	DOUBLE POLE SWITCH
43	UPPER PANEL
44	CONTROL PANEL
45	LOWER PANEL
46	REAR WHEEL
47	REVOLVING WHEEL WITH BRAKE
50	VALVE SET
53	SAFETY VALVE

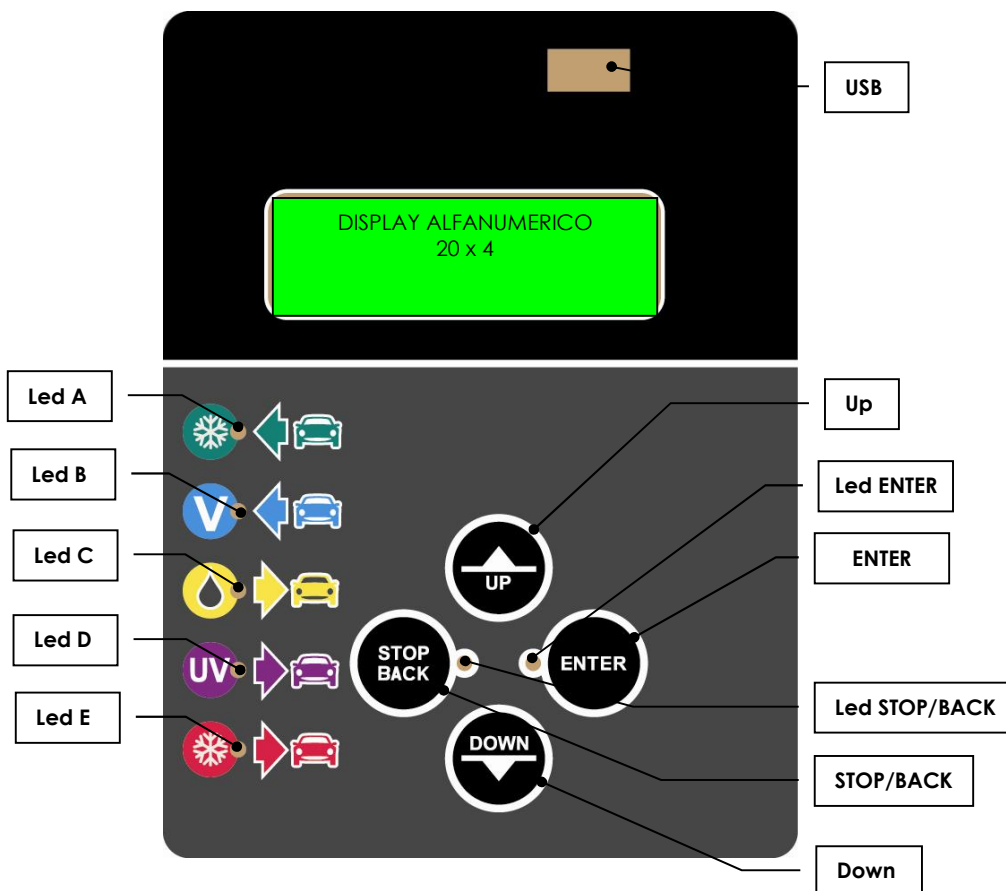

DOWN	Input of programming parameters, descending order / visualization pressure sensor
UP	Input of programming parameters, ascending order / visualization counters
ENTER	Confirm function or menu
STOP/BACK	Select function or menu (Escape o Back)
Led S	Power ON pilot light
Led STOP/BACK	Function change pilot light
Led A	Recycling phase indicator
Led B	Vacuum phase indicator
Led C Led D	UV injection phase indicator
Led E	Filling phase indicator





### **4.3 Technical characteristics**

#### 4.3.1 Main characteristics

Refrigerant:	<b>R134a</b>
Electronic refrigerant scales:	<b>Precision +/- 10 g</b>
Electronic vacuum gauge:	<b>≤ 2 %</b>
LP and HP gauges:	<b>KI. 1.6</b>
RALLY PRO internal container capacity:	<b>12.4 L</b>
Maximum R134a storable quantity:	<b>10 Kg</b>
Compressor cubic capacity:	<b>9 cc</b>
Vacuum pump flow rate:	<b>4.2m<sup>3</sup>/h 2.5 CFM – 70 l/min</b>
Filtering station:	<b>2 filters combined</b>
Dimensions:	<b>900x650x500 mm</b>
Weight:	<b>70 Kg</b>

#### 4.3.2 Power and consumption

Supply voltage:	<b>230 V 50/60 Hz</b>
Power:	<b>770 W</b>

#### 4.3.3 Noise levels

The unit's noise levels have been measured from the operator's position (front).

Measurements recorded:	<b>53.5 dB (A)</b>
Distance of microphone from the ground:	<b>1.40 m</b>
Distance of microphone from the unit:	<b>1.00 m</b>

#### 4.3.4 Technical data concerning the instruments used

(conforming to IEC 651 group 1 requirements).

B & K precision integrating noise meter.

Pre-polarised condenser microphone.

Acoustic level gauge.



## 5 SAFETY

The advanced technology adopted on design and production of **RALLY PRO** makes this unit extremely simple and reliable performing of all operations.

The user is therefore not exposed to any risk provided that the general safety rules indicated below are followed and that the unit is properly used and maintained.

### 5.1 General safety rules

- This unit is intended for use by **professionally trained operators** only. Such operators must have a knowledge of refrigeration, refrigeration systems, refrigerants and the potential hazards that units under high pressure may cause.
- To ensure safe and proper use of the unit, the User must read this manual carefully.
- Check that the type of refrigerant in the A/C system is the same expected for the unit.
- Use only the type of refrigerant expected for the unit, see the identification plate located near the main switch of the unit. Mixing with other types of refrigerant will seriously damage the cooling and refrigeration systems, as well as the service unit.
- It is required that suitable protective equipment such as goggles and gloves be worn – contact with the refrigerant can cause blindness and other physical injuries to the operator.
- Avoid contact with the skin – the low boiling point of the refrigerant (approx. – 30 °C) can cause frost burns.
- Avoid inhalation of vapours from refrigerants.
- Ensure that all the valves are closed before making connections between the unit and an A/C system or an external tank.
- Ensure that the phase has been completed and that all valves are closed before disconnecting the unit. This will prevent release of the refrigerant into the atmosphere.
- Do not modify the safety valve or control system settings.
- Do not use external tanks or storage containers that have not been type-approved or that are not fitted with safety valves.
- Do not leave the unit connected to a power supply unless it is going to be used immediately. Switch off the electrical power supply if the unit is to be out of use for prolonged periods.
- All of the flexible hoses may contain refrigerant at high pressure.
- Disconnect flexible hoses with extreme caution.
- The service unit and A/C systems in vehicles containing refrigerants should not be tested with compressed air. Some mixtures of air and refrigerant have proven to be combustible at high pressure levels. These mixtures are potentially hazardous and there is a risk of fire and explosions that can cause damage to property and personal injury.
- Additional medical and safety information can be obtained from the manufacturers of the lubricants and refrigerants used.
- Remember that the unit must be supervised at all times.
- The unit **must not** be used in potentially explosive environments.
- Do not smoke near the unit.



## 5.2 Guidelines for handling refrigerants

### 5.2.1 Glossary of terms

- **Refrigerant:** A refrigerant fluid solely of the type for which the unit has been designed (check on the identification plate located near the main switch of the unit).
- **A/C system:** Air conditioning system in the vehicle.
- **Unit: RALLY PRO** equipment for the recovery, recycling, vacuum and filling of the A/C system.
- **Operator:** qualified person able to use the unit.
- **External tank:** New, non-refillable refrigerant cylinder, used to fill the internal container.
- **Internal container:** Refrigerant storage tank.
- **Phase:** Execution of an individual function.
- **Cycle:** Execution of each individual phase in sequence.
- **Recovery:** The removal of refrigerant in any condition and its storage in a container outside the A/C system, without necessarily undergoing analysis or treatment of any kind.
- **Recycling:** A reduction in the contaminating substances in used refrigerants through oil separation, the removal of un-condensable gases and their single or multiple passage through elements that enable a reduction in humidity, acidity and particles.
- **Disposal:** Removal of refrigerant to storage, for subsequent destruction or transfer to disposal centres.
- **Vacuum:** Phase in which un-condensable gases and moisture are evacuated from an A/C system solely by means of a vacuum pump.
- **Oil injection:** Introduction of oil into an A/C system for the purpose of maintaining the correct amount specified by the manufacturer.
- **UV additive injection:** Introduction of UV additive into an A/C system to detect any leaks in the A/C system.
- **Filling:** Phase in which refrigerant is introduced into an A/C system in the amount specified by the manufacturer.
- **Flushing :** A\C system cleaning phase from any contaminants by circulation of refrigerant.
- **Leak test with Nitrogen :** filling A/C system with nitrogen in order to detect leakages for pressure decay.
- **Un-condensable gases:** Air accumulated during the refrigerant vaporizing phase, extracted from A/C systems or tanks.



### 5.2.2 Precautions for refrigerant storage

Refrigerant to be removed from a system must be handled carefully in order to prevent or minimise the possibility of mixing different refrigerants.

The unit is specifically designed for the treatment of only one type of refrigerant.

The cylinders used for storing refrigerants must be assigned to specific refrigerants to avoid mixing refrigerants of different types.

The cylinders used must be free of oil and other contaminants and must be clearly marked in order to identify the refrigerants they contain.

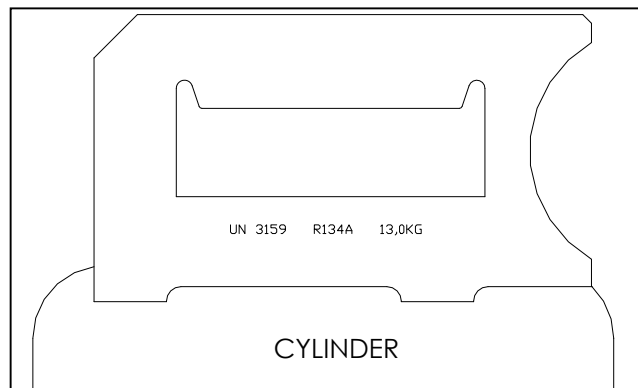

### 5.2.3 Condition of the refrigerant and the system

The history and age of a system can be important factors in deciding whether or not to recycle its refrigerant.

Installation and maintenance procedures carried out during the system's service life have a significant effect on the quality of the refrigerant.

Systems that have not been cleaned or properly evacuated may have high levels of contamination in the refrigerant and the oil. If the system's history is unknown, the refrigerant removed must at least be recycled before being re-introduced into the system.

When operators are unsure of the level of the refrigerant's contamination, preliminary checks can be performed using special kits for measuring acidity and humidity.

### 5.2.4 Recycling capacity

The recycling unit's filter systems must be replaced regularly (Chap. MESSAGES) in order to maintain the efficiency of the recycling unit.

However, even if all factors indicate that recycling of the refrigerant is not necessary, recycling should nevertheless be carried out.

### 5.2.5 General considerations

Before re-introducing refrigerant into the system, the system itself must be evacuated and cleaned.

In order to be sure that the system is free of contaminating agents, all the procedures described in this manual must be followed before introducing the refrigerant.

Clean and maintain the units regularly, especially when highly contaminated refrigerant has been used: it is extremely important that contamination from the previous servicing operation is not transferred to subsequent operations.

### 5.3 Safety devices

The **RALLY PRO** is equipped with the following safety devices:

- Safety pressure switch: Stops the compressor in the event of excessive pressure.
- Safety valves.



**No tampering with the above-mentioned safety devices is permitted.**

### 5.4 Working environment

- Working environment must be compliant with the national laws.
- The unit must be used in an open or well-ventilated environment (at least 4 changes of air per hour).
- The unit has been designed for use at a maximum altitude of 1000 m above sea level, within a temperature range of +5 °C to +50 °C and with maximum humidity of 50% at +40 °C.
- Work in a well-lit environment (the average illumination value for work in mechanical and assembly workshops (for precision work) is 500 – 750 - 1000 lux).
- Work well clear of naked lights, sparks and hot surfaces. At high temperatures, the refrigerant breaks down, releasing toxic and chemical substances that are harmful to operators and the environment.
- Avoid inhaling the refrigerants and oils in the systems. Exposure may cause irritation to eyes and the respiratory tract.



## 6 USE

### 6.1 Unpacking and checking the components

Remove the unit's packaging.

Check that all of the accessory components are present:

- Instruction manual
- 2 cylinder connectors
- Power cable
- Safety kit (gloves, goggles)

### 6.2 Unit handling and storage

Remove the unit from the base pallet of the packaging.

The unit is moved on all four wheels. The two front wheels have brakes.



Although the heaviest components have been assembled on the base in order to lower the centre of gravity, it has not been possible to totally eliminate the **risk of overturning**.

### 6.3 Preparation for use

Once the unit has been moved close to the air conditioning system to be serviced, make sure it is resting on all four wheels on a flat, horizontal surface in order to ensure proper functioning of the scales.

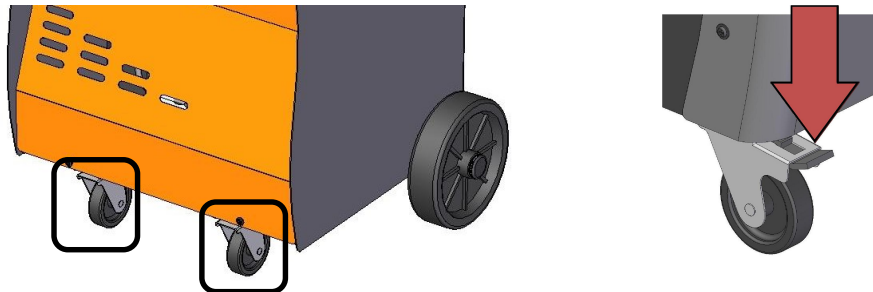

The unit must then be connected to a main supply that conforms to what is indicated on its identification plate (located next to the ON/OFF switch) especially with regard to **voltage, frequency and applicable power**.

 <b>PARTECIPAZIONE S.C.S.</b> Via Comunità Carnica 9 Villa Santina (UD) - Italy  1936	Recovery/recycling/refilling equipment R1234yf				
	Type	HFO B 100-500 132	Electric supply and Power	230 V 50/60 Hz 770 W	
	Serial N°		TS	+5/ +50°C	
	Fluid Group	R1234yf 1	PS	20 bar	
P.E.D.	III cat. Mod B+D	Safety device set pressure	20 bar	Year	

## 6.4 Start-up

Place the Unit on an horizontal position with oil and uv empty containers  
Connect the unit is connected to the main supply, move the ON/OFF switch (42) to the ON (I) position.

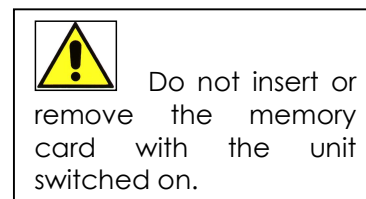
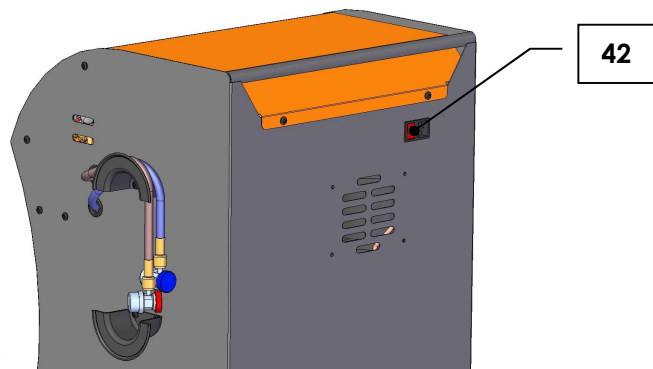

When the Unit is switched on for the first time, it is necessary to select the language among the available ones; the language proposed is Italian.

```
SELECT LANGUAGE  
English
```

```
Enter-Ok Stop-Exit
```

Press **UP** and **DOWN** to select the requested language. Confirm with **ENTER**.

Display shows for few seconds the name of the unit and the software version installed.

```
77L0
```

```
SW xx xx xx xx
```

The display will then show the available resources (stand by):

```
Available refrigerant  
g xxx
```

```
Enter OK
```

## 6.5 Switching Off

To switch the unit off, move the main switch (42) to the OFF (0) position.



## 6.6 Internal tank filling phase



**FOLLOW CAREFULLY THE INSTRUCTIONS BELOW TO PREVENT RELEASE OF THE REFRIGERANT INTO THE ATMOSPHERE**

There are two types of source tank: with dip tube and without dip tube:

- With dip tube,
- Without a dip tube.

Tanks **with dip tube** must remain upright in order to be able to transfer the liquid refrigerant. Use connection **L** (liquid) for this type of tank.

Tanks **without a dip tube** have one valve only. They must therefore be turned upside down in order to transfer the liquid refrigerant.

### Types of tank

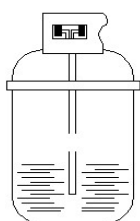

**Tank with dip**



**Tank without dip**

Open the **HP** valve on the control panel.  
Press the **ENTER** key in stand-by mode.

```
Car/customer data  
Skip data          
Other menus        
Enter-Ok Stop-Exit
```

Press the **UP** and **DOWN** keys to select **Other menus**. Confirm with **ENTER** key.

```
Int. tank filling 
Service           
Print             
Enter-Ok Stop-Exit
```

**Print** menu is displayed only if they are present in the Unit the printer.  
Press the **UP – DOWN** keys to select **Int tank filling**. Confirm with **ENTER** key.

```
Connect HP hose
to the external tank.
Open the tank valve
Enter-Ok Stop-Exit
```

Follow the instructions shown by the display. Confirm with **ENTER** key.





Enter the required  
quantity and confirm

g.

Enter-Ok Stop-Exit

Enter the quantity to load inside the tank with the **UP – DOWN** keys.  
Confirm with **ENTER** key.

Please wait !

Stop-Exit

Filling in progress  
recovered quantity

g.

Stop-Exit



The maximum refrigerant quantity storable inside the internal container is 10 Kg. Consider that after the message "Close the external tank valve" the unit could still recover almost 1 kg.

Required quantity ok

Close the external  
tank valve

Enter-Ok Stop-Exit

Follow the instructions shown by the display. Confirm with **ENTER** key.

Wait! Refrigerant

recovery from

HP/LP hoses.

Stop-Exit

Process completed

Enter-Ok

Confirm with **ENTER** key. The display visualizes the stand-by mode.

## 6.7 Draining of incondensable gases

The non-condensable gas drain valve (**33**) is installed to allow gradual evacuation of the non-condensable gases in the internal tank.

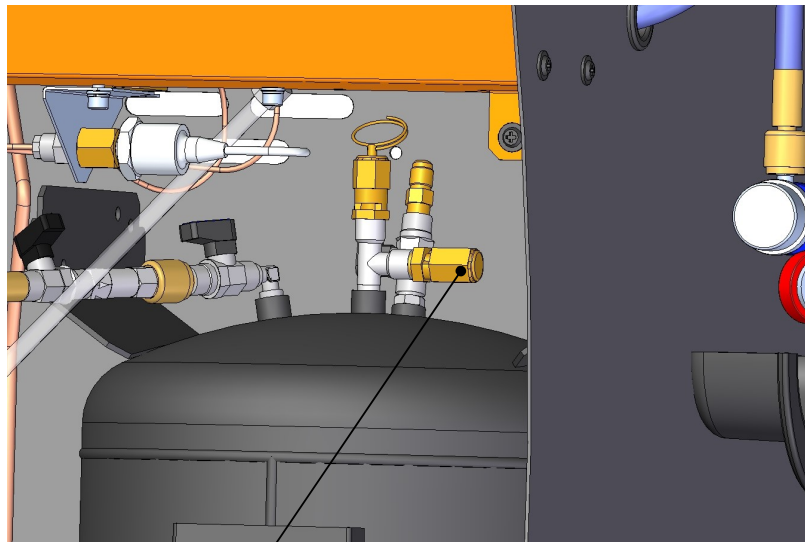

33

It operates **automatically** whenever non-condensable gases are present inside the non-condensable tank and their pressure exceeds the set pressure.

The purpose of the non-condensable gas discharge valve (**33**) is to allow gradual evacuation of non-condensable gases present inside the internal tank once they exceed the set pressure.



## 7 MESSAGES

### 7.1 Malfunction/error messages

**Warning!**  
**Over-pressure**  
**in internal tank**  
**Stop-Exit**

Overpressure in internal container. Wait about 30 minutes and then re-run the recovery/recycling function. Call Customer Service if the problem persists.

**Warning!**  
**Internal tank**  
**filled.**  
**Stop-Exit**

Absolute maximum permitted weight of refrigerant in internal container reached. This value should never be exceeded under any circumstances.

**Warning!**  
**pressure inside the**  
**A/C system.**  
**Recycling start.**

Appears at the start of the vacuum phase if pressure is found in the A/C system. The unit performs a recycling phase.

**A/C system leakage**  
**Continue?**  
**mB.**  
**Enter-Ok Stop-Exit**

A/C system not sealed. This message appears if an increase in the pressure reading occurs during the leakage check. Repair the A/C system. Press the **ENTER** Key to proceed with the next phase. Press the **STOP/BACK** key to return to stand-by mode.

**Insufficient vacuum**  
**Continue?**  
**mb.**  
**Enter-Ok Stop-Exit**

- Appears after a vacuum time of 10 minutes if the pressure in the A/C system has not dropped below **100 mBar**.

Press the **ENTER** Key to continue the vacuum phase.  
Press the **STOP/BACK** key to return to stand-by mode.



**Warning!**  
Insufficient vacuum.

Enter-Ok Stop-Exit

Overpressure during the pressure check phase at the beginning of the oil injection additive injection phases. This phase is only carried out on A/C systems currently under vacuum. Press **ENTER** to confirm. Press the **STOP/BACK** key to return to stand-by mode.

Refr. qty. insuff.  
Perform int. tank  
Filling phase?  
Enter-Ok Stop-Exit

Too low refrigerant quantity inside the internal tank. Press **ENTER** to make a recovery phase from external tank. Press **STOP/BACK** to visualize the next step.

External tank empty  
or valve closed!  
Check  
Enter-Ok Stop-Exit

Appears at the start of the internal tank filling phase if there is no pressure or during the phase if the quantity of refrigerant set has not been reached.

Exceeding recycling  
time  
Continue?  
Enter-Ok Stop-Exit

The maximum time allowed for the recovery/recycling phase has been reached. Check the pressure values on the gauges. If there is pressure, there may be a fault in the unit (call Customer Service). If there is no pressure, there may either be a leak in the A/C system or in the solenoid valves. Press the **ENTER** key to continue the recovery/recycling phase. Press the **STOP/BACK** key to return to stand-by mode.

Exceeding filling  
time  
Continue?  
Enter-Ok Stop-Exit

Turn HP connector  
gear  
counterclockwise  
Enter-Ok

Start A/C system  
Enter-Ok

Open LP  
Valve  
Enter-OK



Appears during the filling phase if the set quantity has not been reached during the maximum planned time if a **HP-LP** A/C system has been selected.

The remaining quantity of refrigerant is sucked by the compressor of the A/C system by following the instructions shown on the display. Following the instruction and then press **ENTER** to continue the filling phase. Press the **STOP/BACK** key to return to stand-by mode.

**Exceeding filling  
time  
Continue?  
Enter-Ok Stop-Exit**

Appears during the filling phase if the set quantity has not been reached during the maximum planned time if only a **HP** A/C system has been selected.

Press the **ENTER** key to continue the filling phase. Press the **STOP/BACK** key to return to stand-by mode.

**Exceeding filling  
time  
Enter-Ok**

Press the **ENTER** key to continue.

**Start A/C system  
Enter-Ok**

Appears during the filling phase if the set quantity has not been reached during the maximum planned time if only a **LP** A/C system has been selected.

The remaining quantity of refrigerant is sucked by the compressor of the A/C system by following the instructions shown on the display.

**usb card  
not found  
Insert usb card  
Enter-Ok Stop-Exit**

Appears if the memory stick is not found when exporting, the following message appears check the presence, operation and correct installation of the memory stick.

**File  
Back up  
Not found  
Enter-Ok Stop-Exit**

Appears if the memory stick is not found during the data restore, the following message appears check the presence, operation and correct installation of the memory stick.



## 7.2 Function messages

Replace filter  
Recycling and  
vacuum pump oil.  
Enter-Ok

Appear at start-up if unit requires programmed maintenance.  
Reset respective work counters after replacing components.  
See paragraph **11.4.3 Counters reset**.

Confirm start  
selected phases?  
Enter-Ok Stop-Exit

Press the **ENTER** key, the unit performs the phases or the programmed cycle.

Process completed  
Enter OK

Press the **ENTER** key, the display shows the stand-by mode.

Now it is available  
a new data base  
version.  
Enter-ok

Please contact  
your dealer.  
Enter-ok

Appears after one year from the first activation of the unit. Press the **ENTER** key, the display shows the stand-by mode.  
Insert a memory stick in the USB port with a new version of the data base and switch ON the unit.  
Enter the password in order to update the data base.

Printer not  
available  
Continue?  
Enter-Ok

 This message appears only if the printer is present (option).

Printer not on line (printer LED flashing). Possible causes are printer lid not closed or lack of paper.  
Press the **ENTER** key to proceed with the next phase. Press the **STOP/BACK** key, the display shows the stand-by mode.  
If the paper has finished, lift the printer lid to prevent print head from burning.



**Only use ISC Systems paper.**  
**The appearance of one of these messages is accompanied by a buzzer sounding.**  
**Press ENTER key to go out.**



## **8 OPERATING DESCRIPTION**

With the unity on stand-by mode, display shows the available refrigerant.

### **8.1 Operating Modalities**

The Unit memorizes the set values concerning the services performed on the A/C plants on the basis of the plate number if an automatic program, or a filling phase, has been carried on; setting a plate number already existing in the unit memory, it is possible to view the previous service data and to repeat the same service.

The Unit is able to operate also in the following cases:

- **Automatic program:**  
It is possible to select a user models previously saved or set the charge refrigerant quantity. The automatic program calculates the vacuum time according to the refrigerant quantity set.
- **User program:**  
the User can select which phases he wants to perform.

After the selection of the preferred program, follow the instruction showed on the display.

From the automatic program you can also select a specific car model from a data base; furthermore a diagnosis system is present and it is able to check the performances of the A/C systems indicating the possible causes of unsatisfactory results.

### **8.2 Modality of programming**

- Press **UP** and **DOWN** keys to select the desired program.
- Press **ENTER** key to confirm the selection.
- Press **STOP/BACK** key to interrupt the function execution and come back on stand-by. Press **STOP/BACK** key to come back to previous screening during settings.



### 8.3 Editing

During the phase of insertion plate number, with any character shown to display, pressing the **ENTER** key he passes to screens it following.

Pressing the **UP** key he departs from the letter A and they is flowed the characters in hourly sense.

Pressing the **DOWN** key he departs from the number 9 and they is flowed the characters in clockwise sense.

Pressing the **ENTER** key he goes to next digit.

Pressing the **STOP/BACK** key he returns to the preceding digit.

Pressing the **ENTER key for 3 seconds** the introduced datum is confirmed.

1	2	3	4	5	6	7	8	9	Space	A	B	C	D	E	F	G	H	I	J	K	L
0																				M	
/																				N	
.																				O	
-																				P	
,																				Q	
+																				R	
*																				S	
)																				T	
(																				U	
'																				V	
&																				W	
%																				X	
\$																				Y	
#	Z																				
«	a																				
!	b																				
z	c																				
y	x	w	v	u	t	s	r	q	p	o	n	m	l	k	j	i	h	g	f	e	d





## 9 PROGRAMS

Connect the **LP-HP** connectors (or the single connector) to the A/C system.  
 Open the connectors (or the single connector) by turning the knob clockwise.  
 The **LP-HP** gauges (or the single pressure gauge) indicate the pressure in the two branches of the A/C system.

Press the **ENTER** key with the display in stand-by mode.

Set plate number   
 Skip data   
 Other menus   
 Enter-Ok Stop-Exit



The software is upgraded frequently, it is possible detecting some differences not described in this manual.

Press the **UP** and **DOWN** keys to select the desired menu. Confirm with **ENTER** key.

Plate number

If you do not want to insert the plate number press **ENTER** key.  
 Insert the plate number with **UP – DOWN** keys. See paragraph **8.3 Editing**.  
 Confirm the plate number pressing **ENTER for 3 seconds**.

### 9.1 Recognition developed services

In case the Unit finds that a service has been performed previously with reference to the same number plate introduced by the User, the display shows the following info.

Plate no.  
 Perform as prev.   
 Prev. service data   
 Enter-Ok Stop-Exit

- Select **PERFORM AS PREVIOUS** and press **ENTER** key to confirm for service start.
- Select **DATA PREVIOUS SERVICE** and press **ENTER** key to view the recorded data.

Press **UP** and **DOWN** keys to scroll the following information:

- Filled quantity
- Vacuum time
- Leak test time
- Pressure increase during leak test time
- Oil injected? Yes/No
- Refrigerant recovered quantity



In some visualizations on the display they are used some slide messages, in the representations of the menu in this manual the message is brought for wide.



Press **ENTER** key to confirm the service. See paragraph **10 START OF PROGRAMMED CYCLES**.  
 Press **STOP/BACK** key to program the service again.

If any service is not found inside the memory of the unity for the same number of plate, or if you chose to program the service again, the display shows:

```
HP/LP couplers      ■
HP coupler only    □
LP coupler only    □
Enter-Ok Stop-Exit
```

Press **UP - DOWN** to select. Confirm with **ENTER**. See paragraph:

- **9.2 Automatic Program**,
- **9.3 User Program**.

### 9.2 Automatic Program

You have access to following screen after having performed the operations brought in the paragraph **9 PROGRAMS**.

```
Automatic program  ■
User program      □
Enter-Ok Stop-Exit
```

Press **UP - DOWN** to select.  
 Confirm with **ENTER** key.

```
Enter filling value ■
User models        □
Enter-Ok Stop-Exit
```

Press **UP - DOWN** to select.  
 Confirm with **ENTER** key.

```
Enter the quantity
g                XXXX
Enter-Ok Stop-Exit
```

Insert the correct refrigerant value with the **UP - DOWN** key and confirm with **ENTER** key.

```
Refr. q.ty g     XXXXX
Vacuum time      XX:XX
```

The vacuum time is calculated in comparison to the filled refrigerant quantity.

Press the **UP** or **DOWN** keys to access the programming of injection Oil – UV phases.  
 See paragraph **9.4 Programming injection oil phase**.

Pressing the **ENTER** key the automatic cycle starts with the inserted data and manual injection oil-UV.

# INSTRUCTION AND MAINTENANCE MANUAL

## Model 131 RALLY 77L0



### 9.2.1 Model Search (Data base)

Select **Search models** to have access to vehicles data base.

```
Enter required q.ty   
Search models 
```

Press the **UP** and **DOWN** keys to select the desired menu.  
Confirm with **ENTER** key.

```
User Models  
> Alfa Romeo <  
Audi  
Enter-Ok Stop-Exit
```

Press **UP** and **DOWN** Key to select the brand desired or to access to the **User models**.  
Confirm with **ENTER** key.

Selecting the brand desired You have to repeat the same operation for all the requested fields of application in order to identify the exact quantity to fill.

```
Refr. q.ty g XXXXX  
Vacuum time XX:XX
```

The vacuum time is calculated in comparison to the inserted refrigerant quantity.  
Press the **UP** or **DOWN** keys to access the programming of injection oil – UV phases.  
See paragraph **9.4 Programming injection oil phase**.

Pressing the **ENTER** key the automatic cycle starts with the inserted data and manual oil - UV injection.

```
> User Models <  
Alfa Romeo  
Audi  
Enter-Ok Stop-Exit
```

Press **UP** and **DOWN** Key to select **User models**. Confirm with **ENTER**.  
See paragraph **9.2.2 User models**.



### 9.2.2 User models

```
> User Models <
Alfa Romeo
Audi
Enter-Ok Stop-Exit
```

Press **UP - DOWN** to select the **User models**. Confirm with **ENTER** key.

```
> User Model 1 <
User Model 2
Enter-Ok Stop-Exit
```

Press **UP - DOWN** to select the user model that you desired. Confirm with **ENTER** key.  
If the selected model had already been planned; the display shows the saved data:

```
Refr. q.ty g   XXXXX
Vacuum time   XX:XX
```

Press the **UP** or **DOWN** keys to access the programming of injection Oil – UV phases.  
See paragraph **9.4 Programming injection oil phase**.

Pressing the **ENTER** key the automatic cycle starts with the inserted data and manual oil – UV injection.

The data previously inserted can be modified pressing **ENTER for 3 seconds** during the data screening.

To set the data of a new user model, place yourself on a free user model and press **ENTER** key.  
The display shows:

```
Mod. :
Refrigerant q.ty. g
Vacuum time:
Enter-Ok Stop-Exit
```

On the display blink the model name  
Insert the name of the user model with **UP** and **DOWN** keys.  
See paragraph **8.3 Editing**.  
Confirm the name of the model pressing **ENTER**.

On the display blink the refrigerant quantity.  
Set with **UP** and **DOWN** keys then confirm pressing **ENTER**.

On the display blink the vacuum time.  
Set with **UP** and **DOWN** keys then confirm pressing **ENTER**.

On the display blink one more time the model name  
If the data are set confirm pressing **ENTER for 3 seconds**

You come back to screen which shows You the choice of the user models.



### 9.3 User Program

You access to following screen after having performed the operation brought in the paragraph **9.Programs**, the display shows:

```
Automatic program    
User program        
  
Enter-Ok Stop-Exit
```

Press the **UP** and **DOWN** keys to select the desired menu. Confirm with **ENTER** key.

```
Recycling?   Yes  
             No  
  
Enter-Ok Stop-Exit
```

Press the **UP** and **DOWN** keys to select. Confirm with **ENTER** key.  
If **NO** option is selected, the display proposes the **vacuum phase**.  
If **Yes** is selected, the display shows:

```
Recycling?      YES  
Pressure increase  
test time min.  x  
Enter-Ok Stop-Exit
```

The display proposes 1 minute pressure increase control before finally completing the refrigerant recovery phase. Set the desired value with **UP – DOWN** keys. Confirm with **ENTER** key.

```
Vacuum phase    yes  
                no  
Enter-Ok Stop-Exit
```

Press the **UP** and **DOWN** keys to select. Confirm with **ENTER** key.  
If **NO** is selected, the display proposes the **charging phase**.  
If **Yes** is selected, the display shows:

```
Vacuum time     20  
Leak test  
time           min. 4  
Enter-Ok Stop-Exit
```

The display proposes a 20 minutes vacuum phase; set the desired value with **UP – DOWN** keys. Confirm with **ENTER** key.

The display proposes a 4 minute leakage control at the end of the vacuum time.  
Set the desired value with **UP – DOWN** keys. Confirm with **ENTER** key.

```
Oil-UV injection?  Yes  
                  No  
  
Enter-Ok Stop-Exit
```

Press the **UP** and **DOWN** keys to select. Confirm with **ENTER** key.



Display shows **filling phase**.

```
Filling phase?   Yes
                  No
```

Enter-Ok Stop-Exit

Press the **UP** and **DOWN** keys to select. Confirm with **ENTER** key.

```
Filling phase
Enter quantity
                  g. 700
Enter-Ok Stop-Exit
```

Set the quantity of refrigerant to be filled with **UP** and **DOWN** keys. Confirm with **ENTER** key.

```
Confirm start
selected phases?
```

Enter-Ok Stop-Exit

Confirm with **ENTER** key.

### 9.4 Programming injection oil phase

```
OIL Injected?   Yes
                  No
```

Enter-Ok Stop-Exit

Press the **UP** and **DOWN** keys to select **YES**. Confirm with **ENTER** key.  
After the vacuum phase the unit will stop in order to make the oil injection.

```
OIL Injected?   Yes
                  No
```

Enter-Ok Stop-Exit

Press the **UP** and **DOWN** keys to select **NO**. Confirm with **ENTER** key.  
After the vacuum phase the unit will stop in order to make the charging phase .



**Warning: visually check that the quantity of oil and UV, in their containers, are sufficient to perform the required injection procedure.**

During performance of the vacuum phase will still modify the choice  
Press the **ENTER** Key for 3 seconds; the display shows the following screen.

```
OIL Injected?   Yes
                  No
```

Enter-Ok Stop-Exit

Confirm with the **ENTER** Key.  
The display shows the remaining time for the vacuum phase.



## 10 START OF PROGRAMMED CYCLES

Open the **LP** and **HP** valves on the control panel, or the single valve, according to the type of A/C system selected.

### 10.1 Recovery/recycling phase

**Recycling start**

**STOP-EXIT**

This message appears on the display for few seconds.

**Recycl. in progress**

**recovered quantity**

**g.**

**Stop-Exit**

When the unit detects that the A/C system is empty, the function stops automatically. A check on the pressure increase inside the A/C system is started

**Pressure increase**

**Test.**

**Sec.**

**Stop-Exit**



If the pressure in the A/C system rises up, the recovery phase starts again automatically.

**Drained oil**

**in progress**

The unit drains the extracted oil into the oil drain container **(21)**.

**Please wait**

**Stop-Exit**

**Recycling completed**

**Recovered quantity**

**g.**

The recovery/recycling phase is now completed.



## 10.2 Vacuum phase

Vacuum in progress.

Time                    xx:xx  
Stop-Exit

When the time is expired, the control of any leakages in the A/C system starts.

Leak test in  
Progress        sec.  
mb    xx  
Stop-Exit

The data is shown on the display for a few seconds.

Vacuum completed

mb.

If the **Oil injection** and the **LP** and **HP** hoses were chosen; at the end of vacuum phase on the display appears:

Close LP  
Valve  
  
Enter OK

Follow the instructions. Confirm with **ENTER** key.

If the **ENTER** key is not pressed, at the end of the vacuum phase, the unit stops and the message appears again.





### 10.3 Oil – UV injection

Inject oil

Enter-Ok Stop-Exit

Rotate the valve to perform the injection.



**Attention visually verify that the oil in the tank covering the end of the injection tube.**

Confirm with ENTER to move to being charged.



### 10.4 Charging phase

Filling phase  
in progress  
quantity g.  
Stop-Exit

Working on only LP port plants, the filling phase is performed intermittently.

The data are visualized during the charging phase.

Filling completed.  
Quantity g.

Process completed

Enter-Ok

Press **ENTER** to confirm.

If the pressure of internal tank is not enough to complete the filling phase, a procedure to fill the remaining quantity with the suction port of the A/C system compressor is carried out. See Paragraph **7 MESSAGES**.

A/C system      Yes  
diagnosis?      No

Enter-OK

If **Yes** is selected You access to diagnosis of the A/C system. See section **11.2 Diagnosis**.

**P.S.** Even without the diagnosis installed we suggest to check A/C system performance. Close **LP – HP** valves. Start the engine and keep it around 1.500/2000 r.p.m. Start the A/C system. Reduce the A/C temperature to a minimum and increase the ventilation speed to the maximum. Wait until the stabilization of the A/C system. Check the pressure on the manometers and the temperature at the central blower. Turn off the A/C system and the engine.

# INSTRUCTION AND MAINTENANCE MANUAL

## Model 131 RALLY 77L0



Disconnect HP/LP  
hoses from A/C

ENTER-OK STOP-EXIT

**Keep the Unit isolated from the A/C System.**

Open LP and HP valves.  
Confirm with **ENTER** key.

**WAIT!** Refrigerant  
recovery from  
HP/LP hoses  
Stop-Exit

The unit performs the recovery from the hoses.

Close LP and HP  
Valves

Enter-OK

Follow the instructions and then press **ENTER**. The display shows the stand-by mode.



## 11 OTHER MENUS

Press the **ENTER** key with the display in stand-by mode.

Set plate number   
Skip data   
Other menus   
Enter-Ok Stop-Exit

Press the **UP** and **DOWN** keys to select the **Other menus**. Confirm with **ENTER** key.

Int.tank filling   
A4 Print   
Print   
Enter-Ok Stop-Exit

Back up/restore   
Diagnosis   
Service   
Enter-Ok Stop-Exit

**Print** menu is displayed only if they are present in the Unit the printer.

Press the **UP** and **DOWN** keys to select the desired menu. Confirm with **ENTER** key.

### 11.1 Filling internal tanks

See paragraph **6.6 Internal tank filling phase**.

### 11.2 Diagnosis

The appropriate function of A/C diagnosis is available both at the end of filling phase and from **Other menus**.

Close LP and HP  
Valves  
Enter-OK

Follow the instructions. Confirm with **ENTER** key.

The display shows the following **only if you access to diagnosis from Other menus**.

Connect HP/LP hoses  
to the A/C system  
Enter-OK Stop-Exit

Follow the instructions. Confirm with **ENTER** key.



Start A/C for  
checking

Enter-OK

To perform a diagnosis in the correct way start the engine and keep it around 1.500/2000 r.p.m. Reduce the A/C temperature to a minimum and increase the ventilation speed to the maximum. Let the A/C System running for 10 minutes. Follow the instructions. Confirm with **ENTER** key.

Check the values reported here below:

- **T.E** external temperature, ( C°)
- **T.I** internal temperature at the main small opening of the A/C, (C°)
- **P.HP** pressure detected by the manometer HP, (bar)
- **P.LP** pressure detected by the manometer LP, (bar)

A/C system diagnosis

P.HP: . P.LP: .

T.I.: . T.E.: .

Enter-Ok Stop-Exit

Insert the required values through the **UP** and **DOWN** keys. Confirm with **ENTER** key after each data entered. When all the values are entered, confirm with **ENTER key for 3 seconds**.

The unit elaborates the data. In case of not reasonable data or unsatisfactory performances, the display shows the different situations that may occur in the A/C system. Each case is indicated with single screen.

Example of diagnosis screen :

Compressor

hoses

reversed

Enter-Ok

 Symbols diagnosis screens:  
-(V.) only for **variable** displacement compressor.  
-(F.) only for **fixed** displacement compressor.

The message scrolls visualizing one of the possible causes. Press **UP** and **DOWN** key for showing the next cases. Press **ENTER** key to continue.



### 11.2.1 Hoses emptying

**Disconnect HP/LP  
hoses from A/C**

**ENTER-OK**

**Keep the Unit isolated from the A/C System.**

Confirm with **ENTER** key.

**Open LP/HP  
Valves**

**Enter-OK**

Follow the instructions. Confirm with **ENTER** key.

**WAIT! Refrigerant  
recovery from  
HP/LP hoses  
Stop-Exit**

The Unit recovers the refrigerant or the vapours of refrigerant still present inside the charging hoses.  
The display shows:

**Close LP/HP  
Valves**

**Enter-OK**

Follow the instructions. Confirm with **ENTER** key.  
The Unit shows the stand-by mode.



### 11.2.2 Suction of refrigerant through the A/C System

Selecting the diagnosis from **Other menus**, at the end of the diagnostic phase, the unit carries out the procedure to let the A/C systems recovering the refrigerant present inside the charging hoses.

**Disconnect HP hose  
from A/C system**

**Enter-Ok**

Follow the instructions. Confirm with **ENTER** key.

**Open LP/HP  
Valves**

**Enter-OK**

Follow the instructions. Confirm with **ENTER** key.

Wait till when the compressor of the A/C system recovers the refrigerant contained in the **HP/LP** hoses. When the pressure detected with the manometers stops to decrease press **ENTER** Key.

**Switch off  
A/C system**

**Enter-OK**

Follow the instructions. Confirm with **ENTER** key.

**Disconnect LP hose  
from A/C system**

**Enter-OK**

Follow the instructions. Confirm with **ENTER** key.

**WAIT! Refrigerant  
recovery from  
HP/LP hoses  
Stop-Exit**

The unit recovers the refrigerant or the vapours still present in the hoses.  
The display shows:

**Close LP/HP  
Valves**

**Enter-OK**

Follow the instructions. Confirm with **ENTER** key.  
The display shows the stand by mode.



### 11.3 PRINTER

This menu is visualized in **Other menu** only if the printer is installed (printer kit, optional for RALLY PRO code 7540005160).

The **RALLY PRO**, with printer, prints a coupon which reports the info concerning each service phase performed; the functions specified here below are also available:

```
Repeat print      ■
Customize data   □
```

ENTER-OK STOP-EXIT

Press the **UP** and **DOWN** keys to select the desired menu. Confirm with **ENTER** key.

#### 11.3.1 Repeat service report

Select **Repeat print** to print a copy of the service report of the last service performed.

#### 11.3.2 Personalization of service report heading

Select **Customize data** to modify the heading of service report.  
The heading is composed of 5 lines and 20 characters.

```
Repeat print     □
Customize data   ■
```

ENTER-OK STOP-EXIT

Press the **UP** and **DOWN** keys to select the desired menu. Confirm with **ENTER** key.  
The display shows the following screen:

```
Enter company
data
ISC Systems
Enter-Ok Stop-Exit
```

You can change one line at a time, select the line to be changed with the **UP** and **DOWN** keys. Confirm with **ENTER** key. The cursor is placed on the first letter of the selected row.

Insert the new heading of the ticket with the **UP** and **DOWN** keys.

See paragraph **8.3 Editing**.

Pressing the **ENTER key for 3 seconds** the introduced line is confirmed.

Proceed as described for the remaining.

When all lines have been completed press **STOP/BACK** key to exit.





## 11.4 Service

Enter password

XX

Insert the code you want with **UP** and **DOWN** keys. Confirm with **ENTER** key.

### 11.4.1 Setting language

Enter password **03**. Confirm with **ENTER** key.

```
SELECT LANGUAGE
  English
Enter-Ok Stop-Exit ↓
```

Press the **UP** and **DOWN** keys to select the desired language. Confirm with **ENTER** key.

### 11.4.2 Date and hour

Enter password **93**. Confirm with **ENTER** key.

```
Edit Date&time
01/01/17
12:00:00
Enter-OK Stop.Exit
```

Press the **UP** and **DOWN** keys to select edit the blinking number, press **ENTER** key to edit the next number.

### 11.4.3 Counters reset

Enter password **05**. Confirm with **ENTER** key.  
the display shows:

```
Refr. recovered q.ty
          g.
Counter reset?
Enter-Ok Stop-Exit
```

Confirm with **ENTER** key, The display shows

```
Press ENTER key
For 3 seconds!
Enter-Ok Stop-Exit
```

Press **ENTER** for 3 seconds

```
Counter reset ok!
Enter-Ok
```

Confirm with **ENTER** key.



## 11.5 A4 Printout

```
Backup data
last job to print
In A4?
Enter-Ok Stop-Exit
```

Confirm with **ENTER** key.

A "Last Job.hst" file is generated and entered on the memory stick, if installed. The file may be imported on a PC and read by means of the "Historical serv & A4 print out.xls" application, which may be downloaded from [www.wiscsystems.it](http://www.wiscsystems.it).

## 11.6 Back up/restore

```
Transfer calibrat.
user models and
parameters?
Enter-Ok Stop-Exit
```

Confirm with **ENTER** key.

```
Transfer from > to
logic board>usb      ■
usb>logic board      □
Enter-Ok Stop-Exit
```

Press **UP -DOWN** to select desired menu. Press **ENTER** to confirm.

 The name of the file generated is represented by the unit serial no. and it will have the .bck extension (e.g. T6000000.bck).

## 11.7 Exporting service history

```
Back up of
previous services?
Enter-Ok Stop-Exit
```

Confirm with **ENTER** key.

A .hst file is generated and entered on the memory stick, if installed. The .hst file may be imported on a PC and read by means of the "Historical serv & A4 print out.xls" application, which may be downloaded from [www.wiscsystems.it](http://www.wiscsystems.it).

 The name of the file generated is represented by the unit serial no. and it will have the .hst extension (e.g. T6000000.hst).



### 11.8 Exporting refrigerant IN/OUT

Back up of previous  
IN/OUT gas report

Enter-Ok Stop-Exit

Confirm with **ENTER** key.

 The name of the file generated is represented by the unit serial no. and it will have the .rio extension (e.g. AP000000.rio).

A .rio file is generated and entered on the memory stick, if installed. The .rio file may be imported on a PC and read by means of the "Refrigerant IN OUT.xls" application, which may be downloaded from [www.iscsystems.it](http://www.iscsystems.it).

## 12 STOP FOR LONG PERIODS

The unit must be stored in a safe place, disconnected from the mains supply and protected from high temperatures, humidity and the risk of collision with other objects that could damage it.

Make sure that the valves on the internal tank are closed.

To put the Unit in use, follow the activation procedure **only after having reopened the internal tank valves**.

## 13 MAINTENANCE

The **RALLY PRO** is an extremely reliable unit, built with top-quality components and using the most advanced production technologies.

For these reasons, maintenance is reduced to a minimum, with long intervals between services. Each periodic maintenance operation is monitored by counters. When these counters reach the prescribed count, the following messages are displayed:

Replace filter  
recycling and  
vacuum pump oil  
Enter-Ok

When the maximum quantity of refrigerant for the dehydrator filter is reached, the filter should be replaced and the relative counter returned to zero, ref. subsection **11.4.3 Counters reset**

At the same as performing the routine maintenance activities, it is recommended that the pressure sensors be calibrated for the zero points of the scales.

An authorized ISC Systems Customer Service Centre should be contacted for maintenance activities (with the exception of those listed below) and the purchase of spare parts.



### 13.1 Changing the vacuum pump oil

The vacuum pump oil must be replaced frequently in order to ensure best performances of the unit.

The message mentioned at point **A** will be displayed when the vacuum pump oil needs to be replaced.

To replace the oil, follow these instructions:



**DO NOT work on parts of the unit that are not specifically mentioned in this section.**

Equipment required:

n°. 1 Screwdriver cross

n°. 2 Hexagonal spanner (12 mm)

1. Disconnect the unit from the power supply.
2. Remove the 4 screws that secure the lower panel to the unit and remove the panel.
3. Place a beaker under the cap (**63**), open the cap and allow all the oil in the vacuum pump to drain out.
4. When the pump has been emptied, screw down cap (**63**) and open the upper cap (**61**).
5. Fill the pump with oil by pouring it into the upper hole (**61**) until it reaches halfway up the inspection glass (**62**).
6. Once the pump has been filled, close the upper cap (**61**).
7. Reset the counter. See paragraph **11.4.3 Counters reset**.

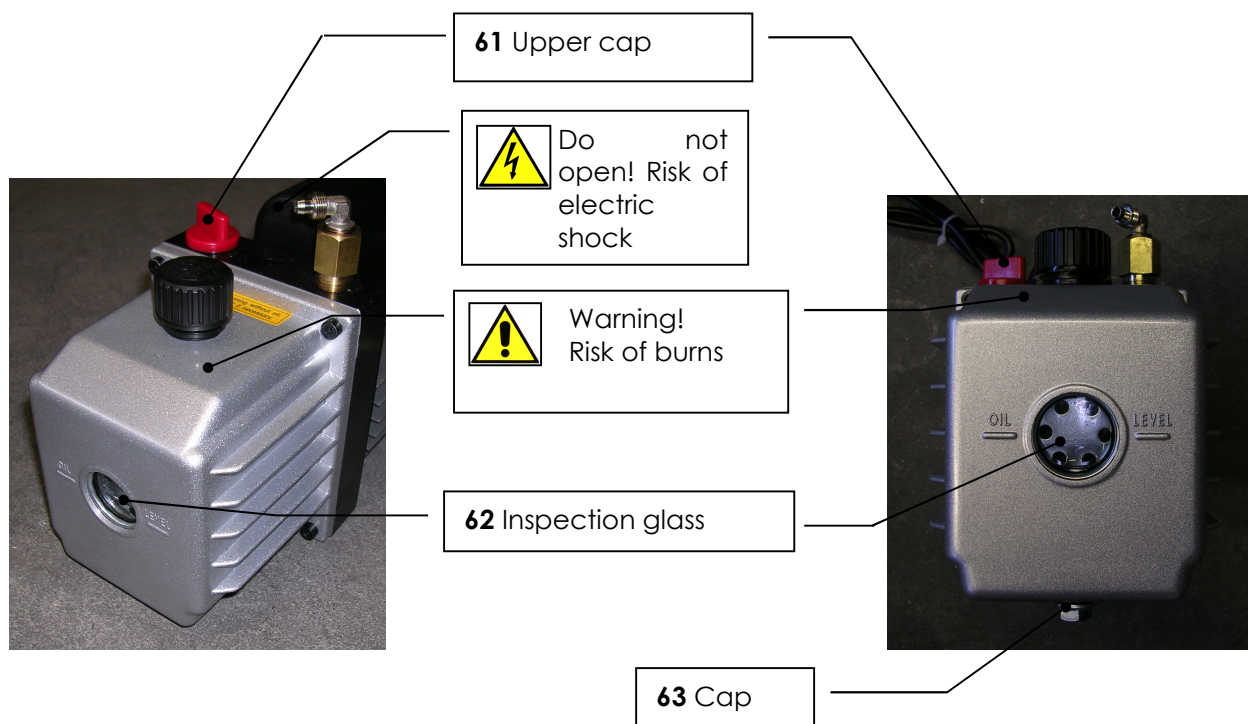

### 13.2 Filter replacement

The dehydrator filter must be replaced when it is no longer able to absorb the humidity present in the recycled refrigerant.

When the filter needs changing, the message indicated under point **B** appears on the display. To change the filter, follow these instructions:



**DO NOT work on parts of the unit that are not specifically mentioned in this section.**

Tools required:

n°1 Cross-head screwdriver

n°2 Hexagonal spanner (19 mm + 17 mm)

1. Remove the 4 screws that secure the lower panel to the unit and remove the panel.
2. Perform a recovery phase.
3. Disconnect the unit from the power supply.
4. Using the hexagonal spanners, undo the 2 nuts connected to the filter (15).
5. Cut the support band.
6. Install the new filter, paying attention to the position of the O-rings and to the arrow direction.
7. Using the hexagonal spanners, tighten the 2 nuts connected to the filter (15).
8. Install a new band.
9. Reset the counter. See paragraph 11.4.3 Counters reset.

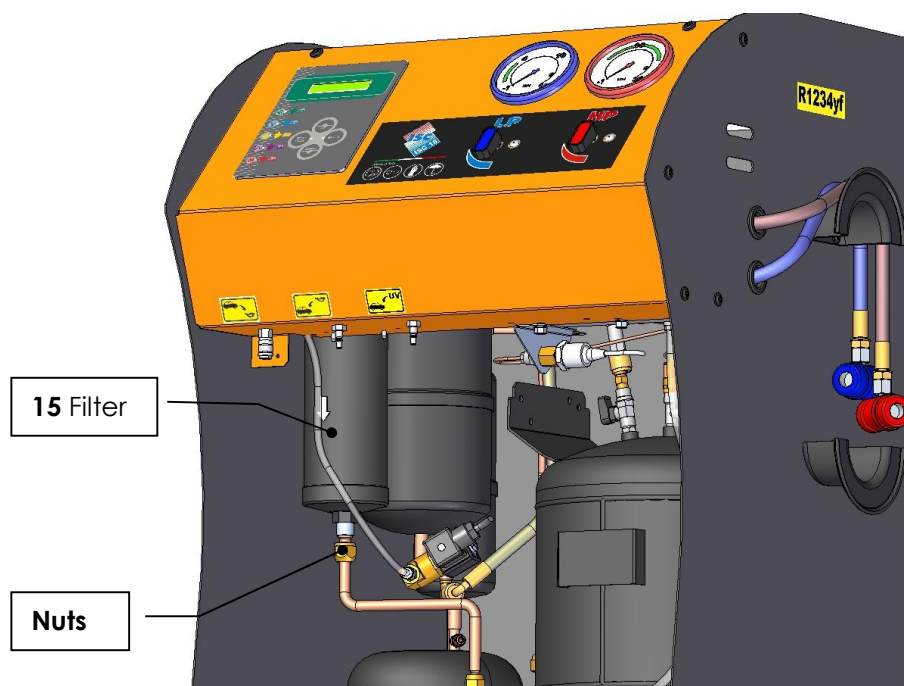



## 14 DISPOSAL

### 14.1 Environmental disposals

This product may contain substances that may be dangerous for the environment and cause diseases for Operators if this equipment has not been disposed in the appropriate way.



We inform You about all necessary Information in order to avoid the release of these such dangerous substances and to optimize the use of natural resources.

The electrical and electronic equipment must not be disposed with normal urban litters but must be sent to specialized harvest for their appropriate treatment.

The symbol of the barred dustbin, that is located on the equipment and on this page, reminds you to pay attention on dispose the product at the end of its lifetime.

In this way, it is possible to avoid that an uncorrect treatment of the substances contained in these such products or an improper use of their parts may cause injurious consequences both for environment and human health.

Furthermore You can give your contribution for recovery, recycling and reutilisation of many row materials contained in these equipments.

For this purpose , both manufacturers and distributors of electric and electronic equipments , organize appropriate harvest centers for the recycling of the same equipments.

At the end of this product lifetime, please contact Your Distributor to have informations about the modalities of harvest.

At the moment of buying a Unit, Your distributor will inform You about the opportunity of giving back - free of charge- another equipment: the necessary requirement is that this equipment has the same typology of use (in this case a Unit for the maintenance of the A/C equipment) and that it can perform the same operative functions of the product previously purchased.

A different disposal of the product from the instruction included in this document will be subjected to the sanctions foreseen by the national laws of the Country where the product will be disposed.

We recommend You to adopt further measures favourable to the environment: recycling the internal and external package of the equipment.

Thanks to Your active cooperation, we can reduce concretely the quantity of natural resources employed for the manufacturing of electric and electronic equipments , minimizing the use of discharges for the disposal of the products and improve the standards of life avoiding that dangerous substances would be released in the environment.

### 14.2 Disposal of recycled material

The refrigerants recovered from systems which cannot be reused must be delivered to the gas suppliers for proper disposal.

The lubricants extracted from systems must be delivered to used oil collection centres.



15 FLOW DIAGRAM

